

## V5197A

### Firing Rate Gas Valve

PRODUCT HANDBOOK



#### APPLICATION

The V5197A are firing rate valves used to provide variable flow control of air, natural gas, liquefied petroleum (LP), and manufactured gases. The V5197A are actuated by a firing rate motor that can be mounted directly on the valves. The V5197A is not applicable as a safety shutoff valve.

The V5197A is specially designed to provide fine control of gas flow in applications where a high turn down ratio is required.

The maximum flow adjustment screw on the bottom of the valve allows adjusting the maximum flow of gas through the V5197 while maintaining the linear modulating characteristics and stroke.

#### FEATURES

- Used with air, natural, manufactured or liquefied petroleum (LP) gases.
- For modulating applications that do not require final shutoff service of firing rate valve.
- Sizes DN65 and DN80.
- Two downstream 1/4 in. BSP threaded pressure taps available.
- Accepts C6097 Pressure Switch mounted directly to flange (downstream pressure tap only).
- Unpainted cast aluminum body.
- Suitable for electric or pneumatic operators with the appropriate linkage.
- May be used with manufacturers own linkage and any approved actuator.
- Adaptors provided for standard Honeywell actuators.
- Flow adjustment screw on bottom of valve controls maximum flow.
- Visual position indicator.

# SPECIFICATIONS

## IMPORTANT

*The specifications in this publication do not include normal manufacturing tolerances; therefore, an individual unit may not exactly match the specifications listed. Also, this product is tested and calibrated under closely controlled conditions, and some minor differences in performance can be expected if those conditions are changed.*

### Models:

V5197A1029; DN65  
V5197A1037; DN80

### Type of Gas:

Air, natural, manufactured, mixed or liquefied petroleum (LP) gases only.

### Pipe Size of the gas train:

2-1/2 in and 3 in.

### Pressure Rating:

Maximum operating pressure of 1 Bar (15 psi).

### Maximum Valve Capacities:

SCFH gas: 0.64 sp. gr. at 1 in. wc pressure drop across valve (flow limit adjustment set at 100% open). See Table 1.

**Table 1. Maximum Flow Capacity  
(natural gas at 0.64 sp.gr.) at 2.5 mBar (1 in. w.c.)  
Pressure Drop Across Valve.<sup>a</sup>**

Pipe Size in mm. (in)	Flow Capacity	
	SCFH	SCMH
64 (2-1/2)	14,800	419
76 (3)	16,900	478

<sup>a</sup> Standard cubic feet per hour (SCFH) and standard cubic meters per hour (SCMH) listed. For other gases, multiply the listed capacity by the square root of (0.64 divided by the specific gravity of the other gas).

### Flow curves:

See Fig. 1 through 4.

NOTE: The percentage settings listed on the figures refer to the setting of the flow adjustment screw on the bottom of the V5197. Pressure drops are shown as solid, broken or dotted lines on the figures.

### Tapping and plug:

Two downstream 1/4 in. BSP taps.  
Plugs : 1/4 in. hex socket.

### Ambient Operating Temperature Rating:

-40°C to +66°C ; (-40°F to +150°F).

### Material:

Cast aluminum body, brass and stainless steel internal parts, NBR seals.

### Mounting:



UNI PN 16; DN65 and DN80.

### Mechanical Strength:

Group 2.

### Maximum flow adjustment (Fig 5):

Located on the bottom of the valve with a 6 mm. (1/4 in) hex key:

To decrease the maximum flow, turn clockwise  to increase the maximum flow, turn counterclockwise .

### Mounting position:

Any position.

### Dimensions:

See Fig. 6.

### Weight:

V5197A1029 6.3 Kg.  
V5197A1037 6.8 Kg.

### Adaptor kits for Honeywell actuators/motors:

KTFRG01 (DCA)  
KTFRG02 (LKS)  
KTFRG03 (MT4000)  
KTFRG04 (MF4000)  
KTFRG05 (Mod IV)

### Approvals:

CE approved  
P.I.N.: 0063BM1882

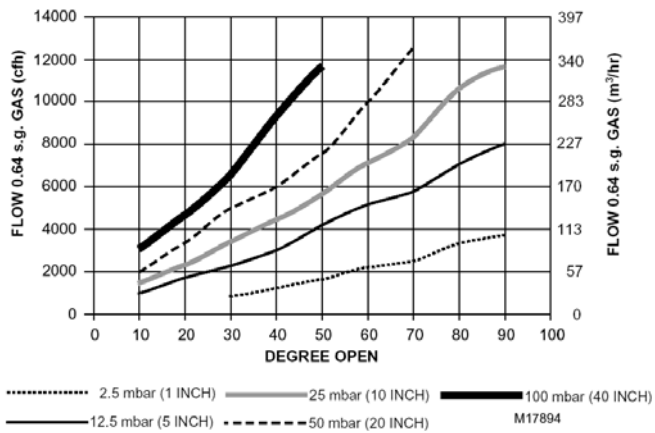

**Fig. 1. V5197A flow curves at stated pressure drops with flow adjustment set at 25%.**

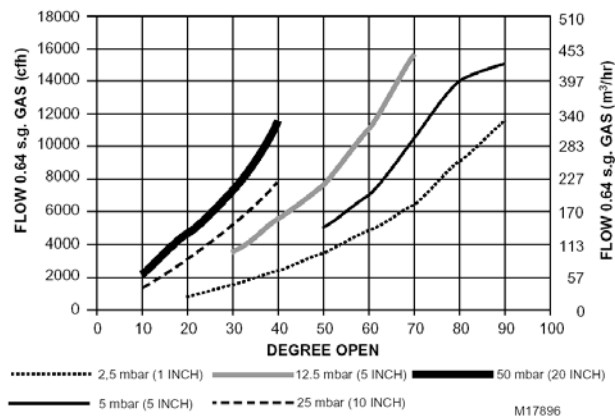

**Fig. 3. V5197A flow curves at stated pressure drops with flow adjustment set at 75%.**

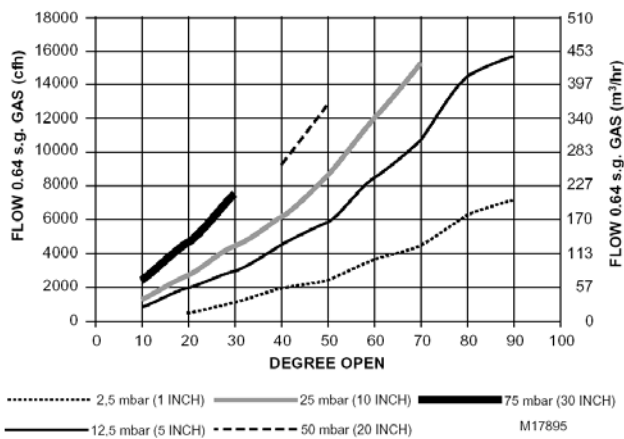

**Fig. 2. V5197A flow curves at stated pressure drops with flow adjustment set at 50%.**

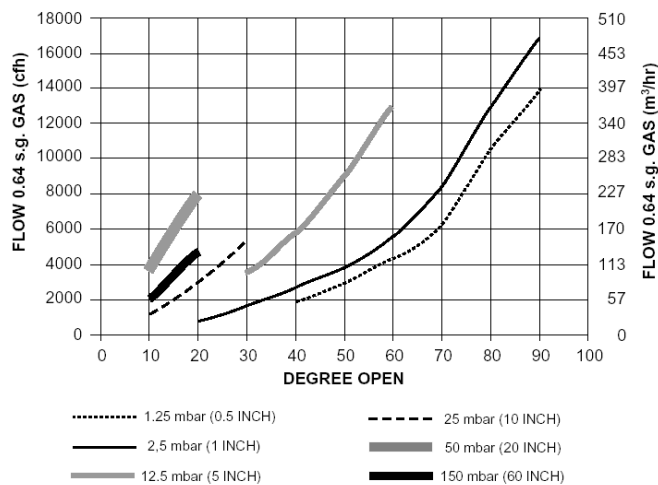

**Fig. 4. V5197A flow curves at stated pressure drops with flow adjustment set at 100%.**

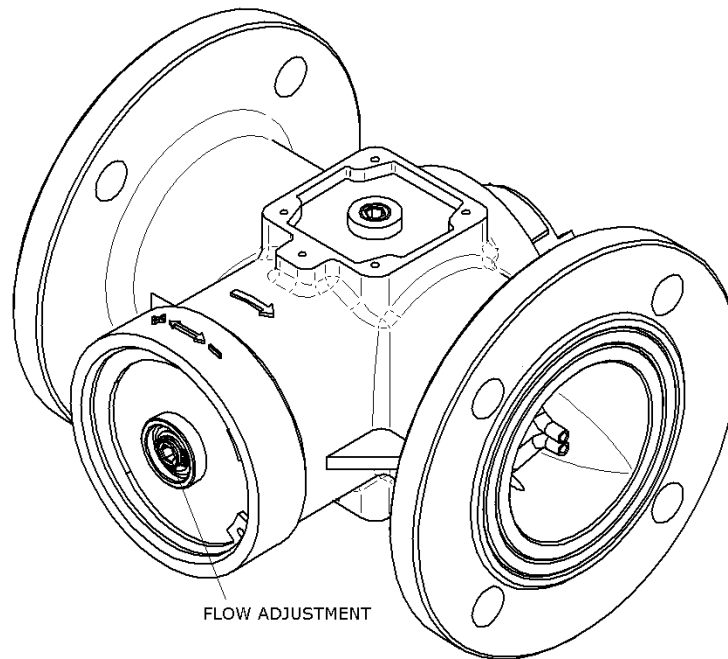

## Installation

### When Installing this product...

1. Read these instructions carefully. Be sure to follow Warning information carefully.
2. Check the ratings given in the instructions and on the product to make sure the product is suitable for your application.
3. Installer must be a trained, experienced flame safeguard control technician.
4. After installation is complete, check out product operation as provided in these instructions.

#### **Explosion Hazard and Electrical Shock Hazard. Can cause explosion, serious injury or death.**

1. Turn off gas supply before starting installation.
2. Disconnect power supply for valve actuator (if applicable) before beginning installation. More than one disconnection can be involved.

### Installing the V5197A

Allow sufficient clearance for assembling the motor and linkage (if applicable), and for general serviceing.

#### **IMPORTANT**

*Install the valve so the arrow on the valve body points in the gas flow direction. Make sure the two flange gaskets (not provided in) are properly positioned and seated at the inlet and outlet flange connections.*

1. Install the V5197 Valve so the arrow on the valve body points in the gas flow direction.

NOTE: Normally, the V5197 will be located downstream of the safety shutoff valve(s) in the gas train.

2. Connect the V5197 Valve to the safety shutoff valve (SSOV) using the bolts, nuts and lockwashers.

NOTE: Tightening torque for flange nuts/bolts:  
34 Nm (25 ft-lb)

3. Assemble the downstream gas piping:
4. Mount the the selected actuator on the V5197 Valve and secure the actuator to the mounting bracket.
5. Wire the selected actuator according to instructions.
6. Restore power to the system.
7. Test proper wiring of the actuator before gas is supplied to gas train.

**IMPORTANT**

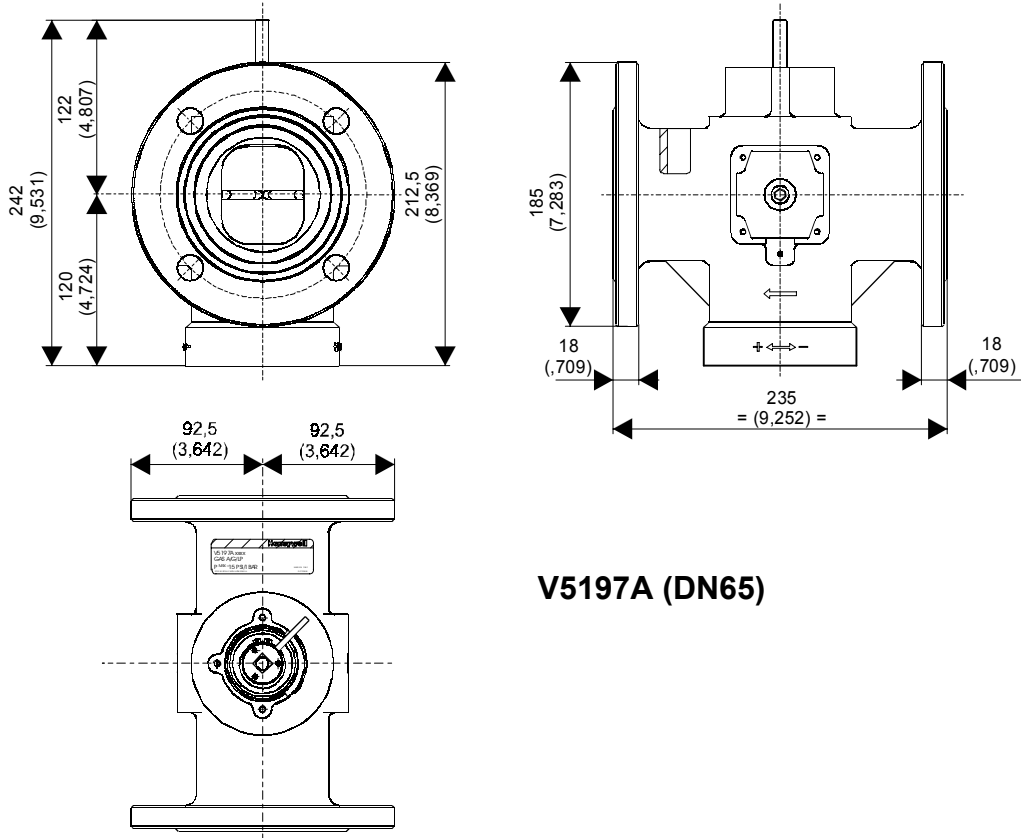

**V5197A (DN65)**

*Install the valve so the arrow on the valve body points in the gas flow direction.*

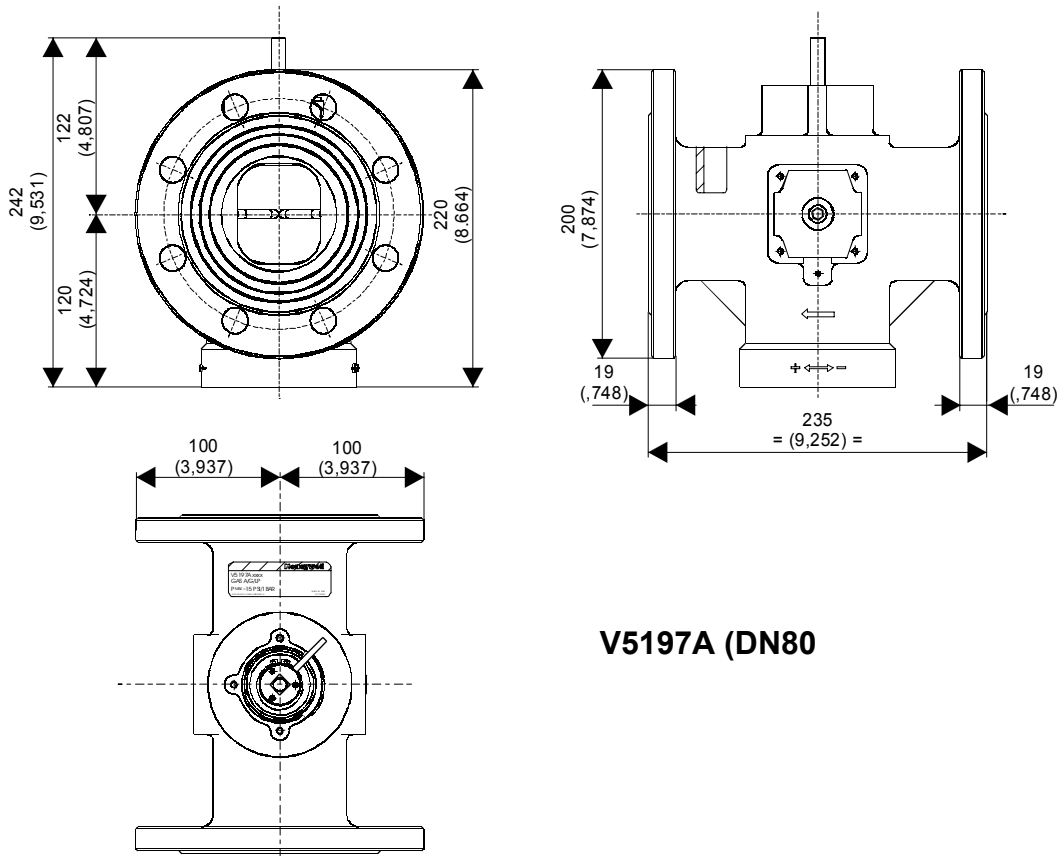

**V5197A (DN80)**

*Fig. 6. V5197A Firing Rate Gas Valve dimensions in mm. (in).*

## CHECKOUT AND OPERATION

### Checkout

**Explosion Hazard and Electrical Shock Hazard.  
Can cause explosion, serious injury or death.**

1. Do not allow fuel to accumulate in the combustion chamber for longer than a few seconds without igniting. An explosive mixture can result.
2. Do not put the system into service until you have satisfactorily completed the following Valve Leak Test, all applicable tests described in the Checkout section of the instructions for the flame safeguard control, and any other tests required by the burner manufacturer.
3. All tests must be performed by a trained, experienced flame safeguard control technician.
4. Close all manual fuel shutoff valves as soon as trouble occurs.

After the installation is completed, cycle the valve several times with the manual fuel shutoff cock closed. Make sure the valve and actuator function properly. Perform the Valve Leak Test before putting the valve into service.



### Valve Leak Test

This is a test for checking the leakage tightness of the firing rate gas valve only. It should be performed only by trained, experienced flame safeguard control technicians during the initial startup of the burner system, or whenever the valve is replaced (see Service Information section). It is recommended that this test also be included in the scheduled inspection and maintenance procedures.

NOTE: Additional leakage and closure tests may be required for other gas train components (for example, safety shutoff valves [SSOV]).

1. Close the downstream manual gas valve(s).
2. Energize the valve train to apply gas pressure.
3. Test with good quality leak detection spray.
4. Restore the system to normal operation.

### Operation

A V5197A Firing Rate Gas Valve is operated by an actuator. The valve opens counterclockwise  and closes clockwise . When closed, the valve does not totally seal off the gas flow and has no safety shutoff function. For further information, refer to the actuator instructions.

Make sure that the actuator does not force the V5197 Valve beyond the limits of the valve stroke (90 degrees). This can damage or destroy the valve position indicator setscrew.

## SERVICE INFORMATION

**Explosion Hazard and Electrical Shock Hazard.  
Can cause explosion, serious injury or death.**

1. Turn off the gas supply and disconnect all electrical power to the valve actuator before servicing.
2. Properly position and seat the gaskets in ends of the valve body to prevent a hazardous gas leak.

### **IMPORTANT**

*Only trained, experienced flame safeguard control technicians should attempt to service or repair flame safeguard controls and burner assemblies.*

### **Scheduled Inspection and Maintenance**

Set up and follow a schedule for periodic inspection and maintenance for the burner, all other controls and the valves. It is recommended that the valve leak test in the Operation and Checkout section be included in this schedule. Refer to the instructions for the primary safety control and safety shutoff valve(s) for more informati



**Honeywell**

---

**Automation & Control Solutions**

Control Product  
Satronic AG  
Honeywell-Platz 1  
CH-8157 Dielsdorf  
Switzerland  
Phone: +41 1 855 22 11  
Fax: +41 1 855 22 22